

Rockliner

Typical 4-sided snaplock casing

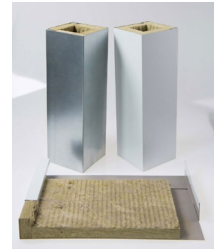

Fabricated in one U shaped section with a snap on lid or 4 pieces with snap-lock joints as shown.

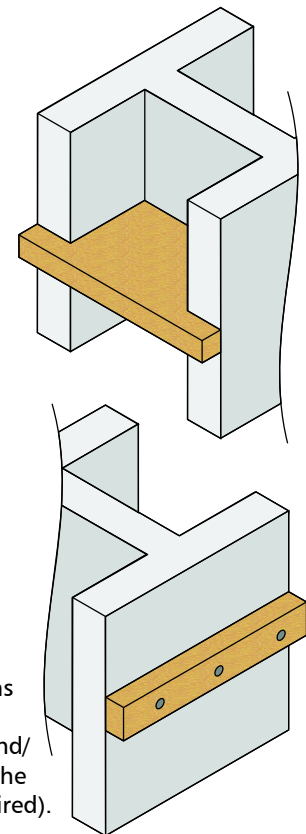
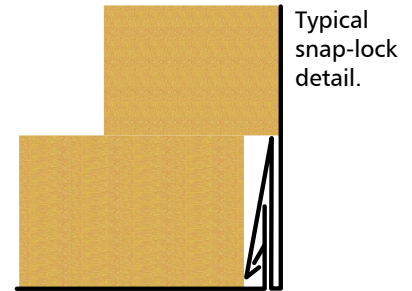
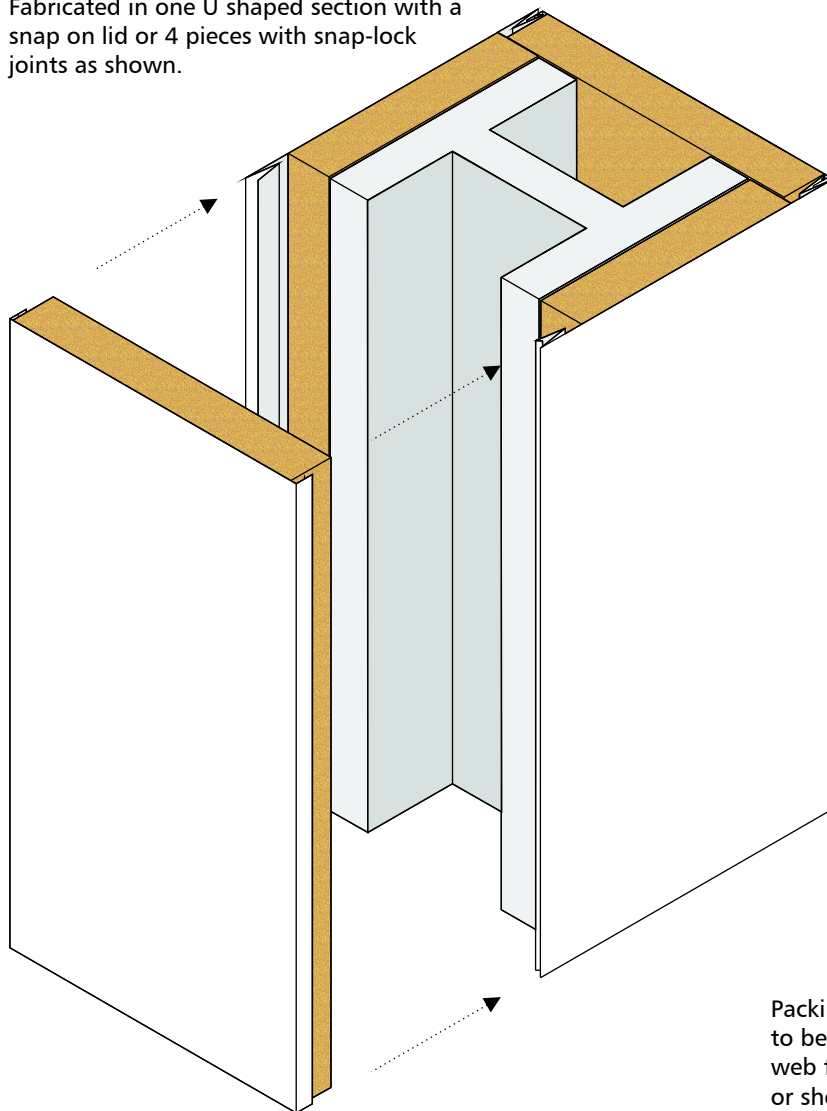

MATERIAL

Metal:
Internal casings
- 0.6mm steel.

Finishes:
Unfinished, spangle galv,
plastisol coated, PVF2
coated, powder coated,
polyester coated.
Various colours available.

Lining:
Spiralite to provide required
fire rating.

Fixings:
No fixings required.

The information contained in Cryotherm data sheets is believed correct at the time of publication. Whilst we will endeavour to keep our publications up to date, readers will appreciate that between publications there may be pertinent changes in the law, or other developments affecting the accuracy of the information provided.

Date of this revision: 25/11/20